

Wall Mounted Touch Panel

- Touch panel RGBW PWM constant voltage controller.
- Ultra sensitive high strength glass touch panel with touch color slide in the middle.
- Compatibility with RF 2.4G single zone or multiple zone remote control.
- White & Black glass panel available.

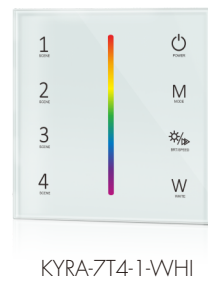

CE RoHS RED

Technical Parameters

Input and Output		Environment		Safety and EMC	
Input voltage	12-24VDC	Operation temperature	Ta: -30°C ~ +55°C	EMC standard	EN 62479:2010 ETSI EN 301 489-1 V2.2.3 ETSI EN 301 489-17 V3.2.4
Input current	12.5A	Case temperature (Max.)	Tc: +85°C	Safety standard	EN 61347-1:2015+A1:2021 EN 61347-2-13:2014+A1:2017
Output voltage	4 x (12-24)VDC	Package		Radio Equipment	ETSI EN 300 328 V2.2.2
Output current	4CH,3A/CH	Size	L112 x W112 x H50mm	Certification	CE RED
Output power	144-288W	Gross weight	0.231kg		
Output type	Constant voltage				
PWM frequency	1KHz				

Mechanical Structures and Installations

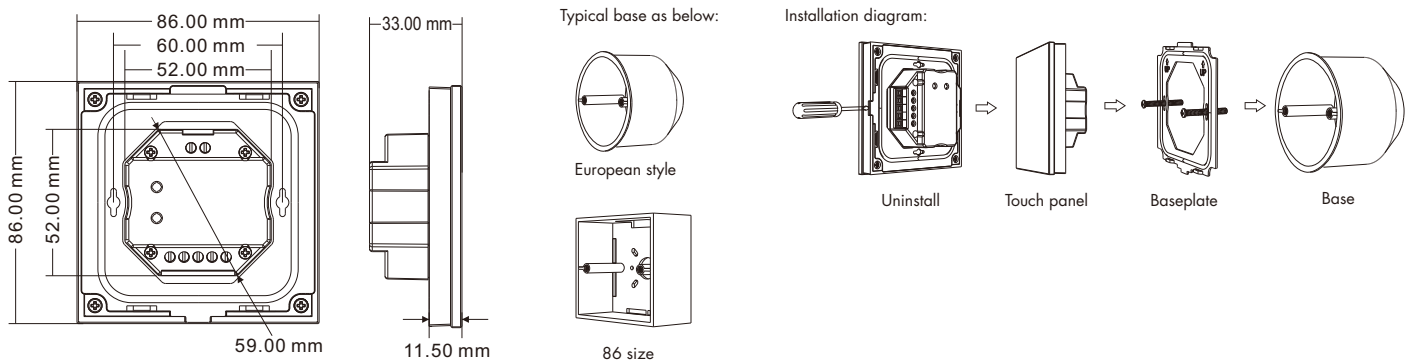

Match Remote Control (two match ways)

The touch panel controller can also match with the RF remote (optional). End user can choose the suitable match/delete ways. Two options are offered for selection:

Use On/Off key

Match:
Turn on light, turn off, immediately press the On/Off key of the panel for 5s, then press on/off key (single zone remote) or zone key (multiple zone remote) of the RF remote within 5s. The LED indicator fast flash 3 times means match is successful.

Delete:
Turn on light, turn off, immediately press the On/Off key of the panel for 10s, delete all matched RF remote. The LED indicator fast flash 6 times means all matched remotes were deleted.

Use Power Restart

Match:
Switch off the power, then switch on power, repeat again, immediately short press on/off key (single zone remote) or zone key (multiple zone remote) 3 times on the remote. The light blinks 3 times means match is successful.

Delete:
Switch off the power, then switch on power, repeat again, immediately short press on/off key (single zone remote) or zone key (multiple zone remote) 5 times on the remote. The light blinks 5 times means all matched remotes were deleted.

Key Function

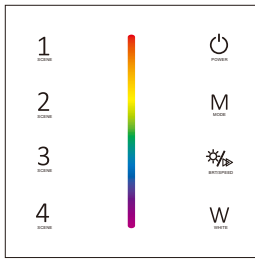

- Turn on/off light.
- Color slide.
- Adjust dynamic mode speed or static color brightness, 10 levels.
- M** — Short press play 10 built-in dynamic mode, long press 2s run mode-cycle.
- W** — Short press turn on/off W channel, long press adjust W channel brightness.
- 1 2 3 4** — 4 Scenes, short press recall scene.
Long press 2s to save the current color into 1/2/3/4.

Turn on key tone: Long press power key for 5s when light is off, will turn on or turn off key tone(T1-1, T2-1 without key tone).

Wiring Diagram

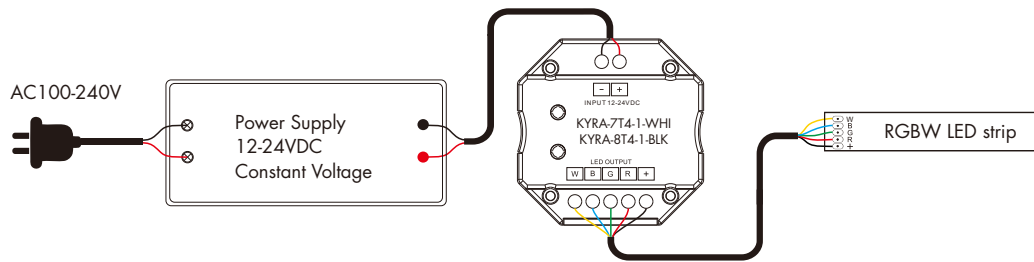

RGB/RGBW Dynamic Mode List

No.	Name	No.	Name
1	RGB jump	6	RGB fade in and out
2	RGB smooth	7	Red fade in and out
3	6 color jump	8	Green fade in and out
4	6 color smooth	9	Blue fade in and out
5	Yellow cyan purple smooth	10	White fade in and out